

# STENKIM® YOUR PARTNER ON SITE

We provide solutions for all types of concrete pavement projects, no matter how demanding the requirements. We understand that your concrete needs to be strong, durable, and workable while remaining cost-effective. We stand by you through severe weather conditions, demanding loads, tight schedules, and budget constraints. We offer a comprehensive range of premium products for every stage of the paving process.

## CONCRETE ADMIXTURES

**StenMix®** concrete admixtures are engineered for high-performance, strong, and durable concrete with enhanced workability. The range includes setting modifiers, air-entraining admixtures, antifreeze additives, water reducers, and superplasticizers.

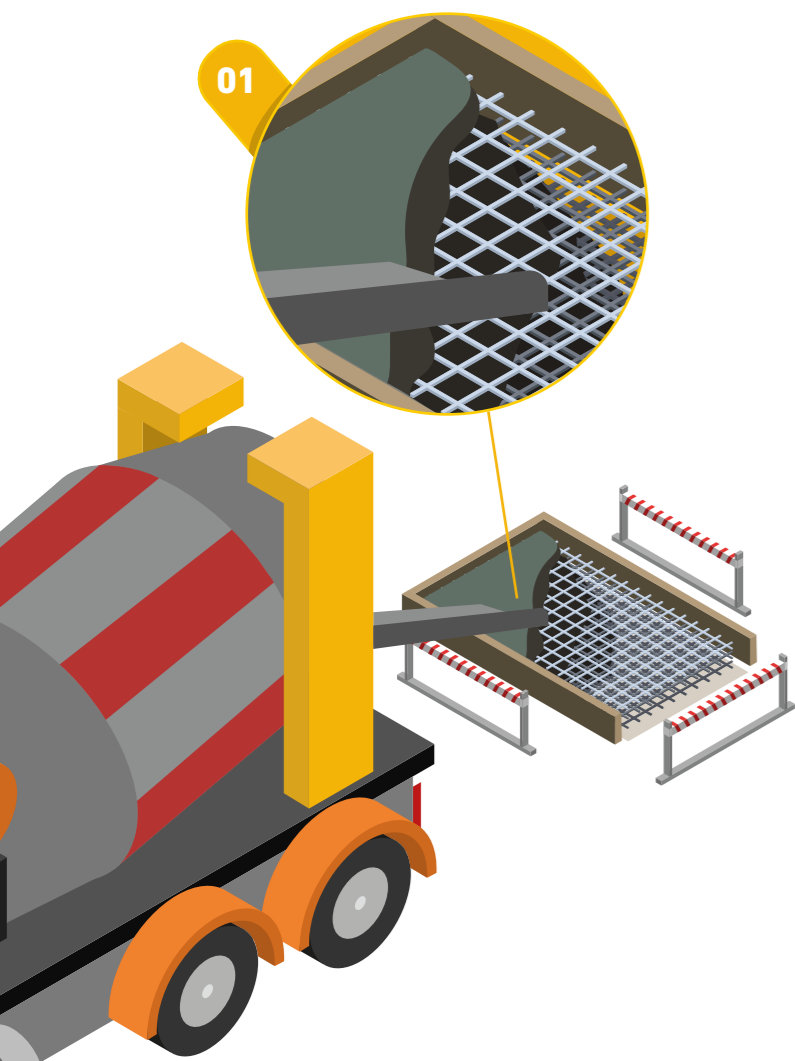

01

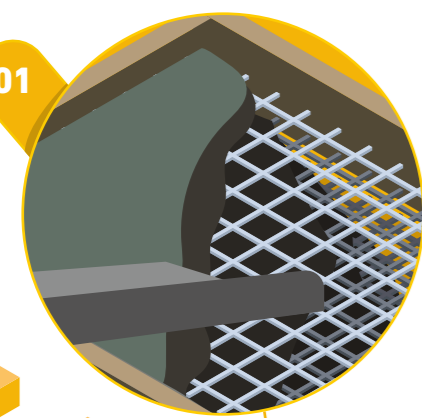

## CURING AGENTS

**StenCure®** provides economical and effective solutions to prevent water loss and shrinkage cracks in fresh concrete. Curing compounds based on polymers and paraffin are available, along with non-pigmented and white pigmented versions, to provide the most suitable material for your site conditions.

02



## REPAIR AND REINFORCEMENT MATERIALS

**StenCare®** products offer robust and reliable anchoring, repair and reinforcement solutions. Polyurethane, epoxy putty and mortars are available for high strength concrete repair. MMA and epoxy anchors for rebar and dowel anchoring are also available.

03

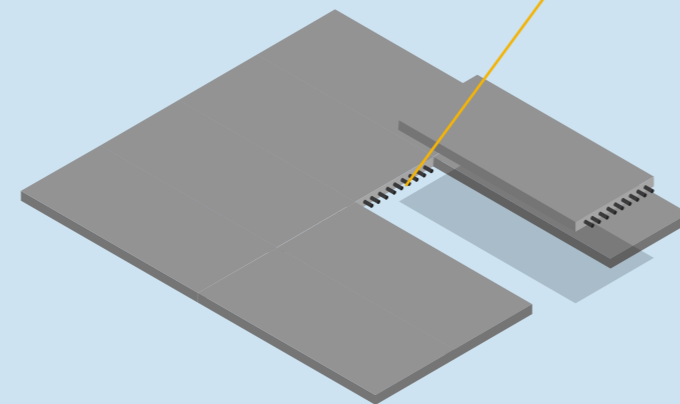
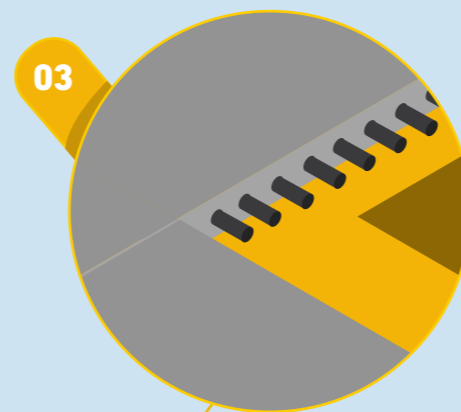

## JOINT AND CRACK SEALANTS

**StenSeal®** is a versatile range of sealants designed to withstand the most demanding conditions. These highly resistant sealants provide long service life under heavy traffic, chemical exposure, and outdoor conditions. **Stenkim®** produces a comprehensive range of polyurethane, silicone, SBS, and polysulfide sealants. We also provide certified jet fuel resistant sealants for aprons, taxiways, runways, and refueling areas.

05

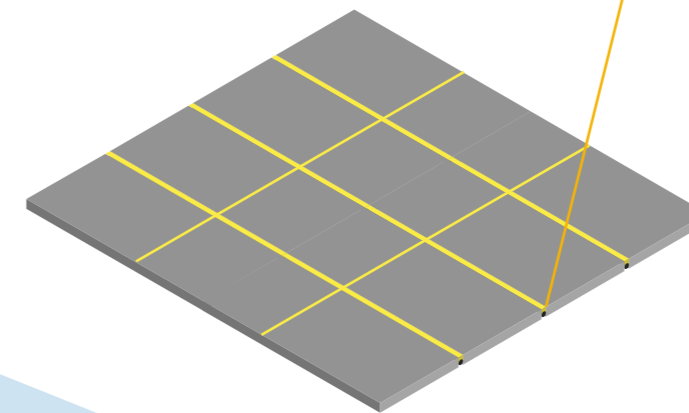
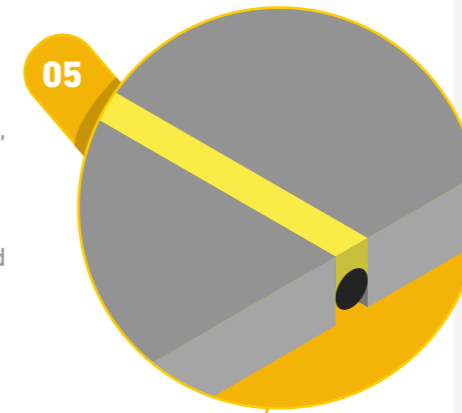

## ROAD MARKING PAINTS

**StenCoat®** road marking paints are specifically designed for airport and highway pavements. These highly durable and cost-effective paints enhance pavement safety through improved visibility and skid resistance. Their fast-drying formula minimizes downtime.

06

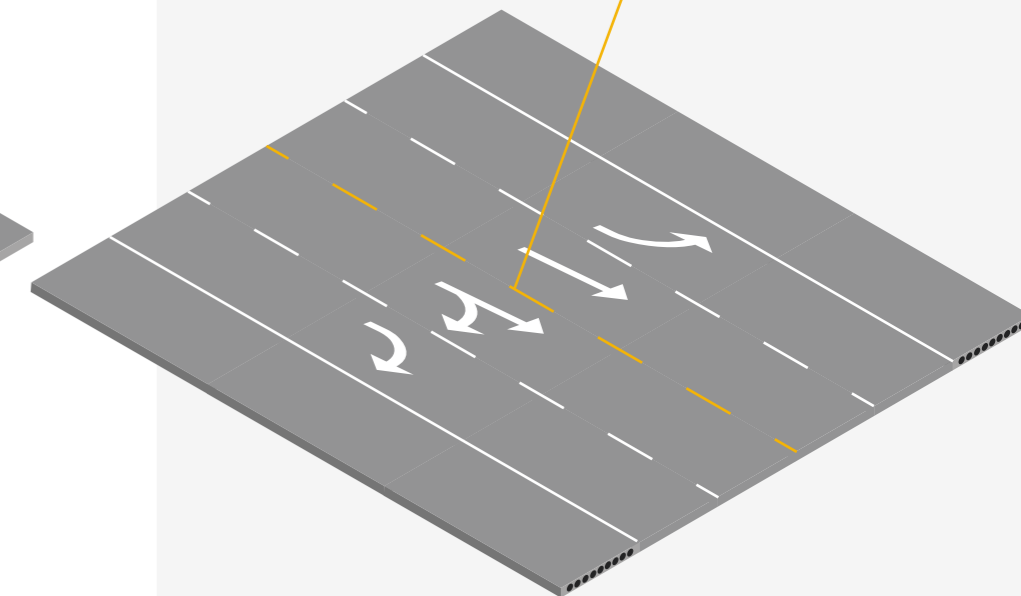

## MANY MORE

- Our product portfolio also contains;
- Decorative and heavy-duty epoxy and polyurethane floor coatings,
  - Injection materials for mining and tunneling projects,
  - Waterproofing and water repelling materials,
  - And many more...
- For our full list of products check our website [www.stenkim.com](http://www.stenkim.com)